

EQUINOX

Hornet

User Manual



Order code: EQLED450

WARNING

FOR YOUR OWN SAFETY, PLEASE READ THIS USER MANUAL CAREFULLY BEFORE YOUR INITIAL START-UP!

- Before your initial start-up, please make sure that there is no damage caused during transportation.
- Should there be any damage, consult your dealer and do not use the equipment.
- To maintain the equipment in good working condition and to ensure safe operation, it is necessary for the user to follow the safety instructions and warning notes written in this manual.
- Please note that damages caused by user modifications to this equipment are not subject to warranty.

CAUTION!
KEEP THIS EQUIPMENT AWAY FROM RAIN, MOISTURE AND LIQUIDS



CAUTION!
TAKE CARE USING THIS EQUIPMENT!
HIGH VOLTAGE-RISK OF ELECTRIC SHOCK!!



CAUTION!
LASER LIGHT - AVOID DIRECT EYE EXPOSURE
CLASS 3B LASER



IMPORTANT:

The manufacturer will not accept liability for any resulting damages caused by the non-observance of this manual or any unauthorised modification to the equipment.

- Never let the power cable come into contact with other cables. Handle the power cable and all mains voltage connections with particular caution!
- Never remove warning or informative labels from the unit.
- Do not open the equipment and do not modify the unit.
- Do not connect this equipment to a dimmer pack.
- Do not switch the equipment on and off in short intervals, as this will reduce the system's life.
- Only use the equipment indoors.
- Do not expose to flammable sources, liquids or gases.
- Always disconnect the power from the mains when equipment is not in use or before cleaning! Only handle the power-cable by the plug. Never pull out the plug by pulling the power-cable.
- Make sure that the available mains supply voltage is between 100~240V AC, 50/60Hz.
- Make sure that the power cable is never crimped or damaged. Check the equipment and the power cable periodically.
- If the equipment is dropped or damaged, disconnect the mains power supply immediately and have a qualified engineer inspect the equipment before operating again.
- If the equipment has been exposed to drastic temperature fluctuation (e.g. after transportation), do not connect power or switch it on immediately. The arising condensation might damage the equipment. Leave the equipment switched off until it has reached room temperature.
- If your product fails to function correctly, stop use immediately. Pack the unit securely (preferably in the original packing material), and return it to your Pro Light dealer for service.
- Only use fuses of same type and rating.
- Repairs, servicing and power connection must only be carried out by a qualified technician. THIS UNIT CONTAINS NO USER SERVICEABLE PARTS.
- This lighting fixture is for professional use only - it is not designed for or suitable for household use. The product must be installed by a qualified technician in accordance with local territory regulations. The safety of the installation is the responsibility of the installer. The fixture presents risks of severe injury or death due to fire hazards, electric shock and falls.
- Warning! Risk Group 2 LED product according to EN 62471. Do not view the light output with optical instruments or any device that may concentrate the beam.
- WARRANTY: One year from date of purchase.

OPERATING DETERMINATIONS

If this equipment is operated in any other way, than those described in this manual, the product may suffer damage and the warranty becomes void. Incorrect operation may lead to danger e.g: short-circuit, burns and electric shocks etc.

Do not endanger your own safety and the safety of others!

Incorrect installation or use can cause serious damage to people and/or property.

Please note: These fixtures are intended for stage lighting and entertainment applications only, and are not intended for extended periods of use, including but not limited to house-light, industrial or architectural applications and should only be operated with short duty cycles.

Proper Usage

This product is for overhead use only. For safety purposes, we recommend mounting lighting effect products with lasers, on level surfaces or sturdy overhead supports using suitable hanging clamps and safety cables. Please contact us for more information on appropriate mounting hardware.

International laser safety regulations state that laser products must be operated as per the example below; with a minimum of 3m (9.8ft) vertical distance between the floor and the lowest laser. Additionally, 3m of horizontal distance is required between laser and the audience or other surroundings.

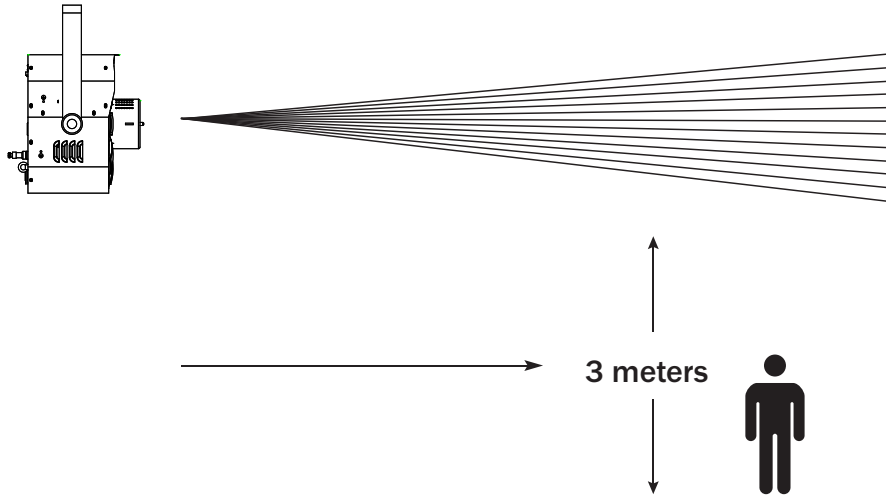

CAUTION: Laser radiation

Avoid pointing directly towards eyes. Laser output can cause injury if viewed directly. This product is a Class 3B laser and should only be installed and used by persons who are trained in the management of laser radiation and are able to operate in accordance with the guidance given by the Health and Safety Executive (HSE) in "The Safety of Laser Lighting Displays". Information on this guidance can be found on the following website: <https://www.hse.gov.uk/pubns/indg224.htm>

Laser Interlock and Key

This product is supplied with an interlock and key to prevent the laser being operated unless the interlock is inserted and the key is turned to the **ON** position.

For the laser to function you must;

- Insert the laser lock and secure this with the threaded ring.
- Insert the laser key and turn it to the **ON** position.

ALWAYS turn the key to the **OFF** position and remove it key before leaving this product unattended to avoid accidents/injuries.

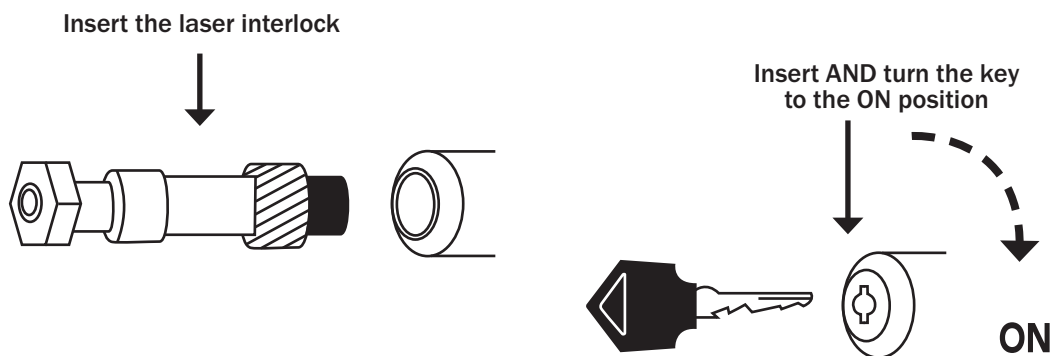

Hornet

The Hornet is a feature packed 4-in-1 unit combining multi-beam, wash, strobe and laser effects to cover large areas in an array of colourful patterns and effects. A magnitude of built-in shows can be accessed via the menu or handy IR remote, allowing the user to simply plug and play. Different DMX modes allow for further individual control of effects and W DMX USB compatibility is on-board for wireless convenience. The Hornet is supplied with a dual bracket for multiple rigging or floor standing applications.

- Multi-beam: 5 x 3W five-colour LEDs (RGBWA)
- Wash: 8 x 2W quad-colour LEDs (RGB+UV)
- Strobe: 12 x 0.5W white 5050 SMD LEDs
- Laser: 650nm/100mW (red) laser diode, 520nm/30mW (green) laser diode
- Coverage angle: Derby - 65°, Wash - 46°, Strobe - 71°, Laser - 82°
- DMX channels: 2 or 19 selectable
- W DMX USB compatibility for wireless primary/secondary or DMX control
- Auto, sound active and primary/secondary modes
- 0 - 100% dimming
- Variable strobe
- Bracket allows for multiple rigging or floor standing applications
- 4 button menu with LED display
- PowerTwist TR1 input/output
- 3-Pin XLR input/output
- Fan cooled
- Supplied with IR remote



Specifications	
Power consumption	47W
Power supply	100~240V, 50/60Hz
Fuse	T1.6A 250V
Dimensions	333 x 315 x 252mm
Weight	4kg
Order code	EQLED450

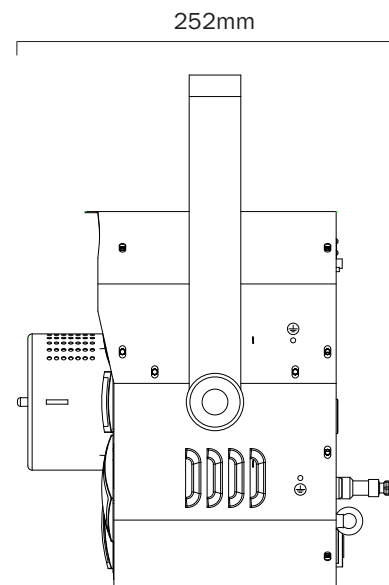
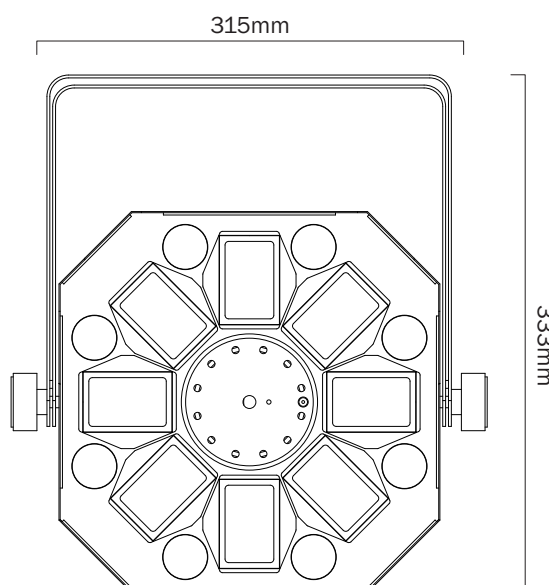

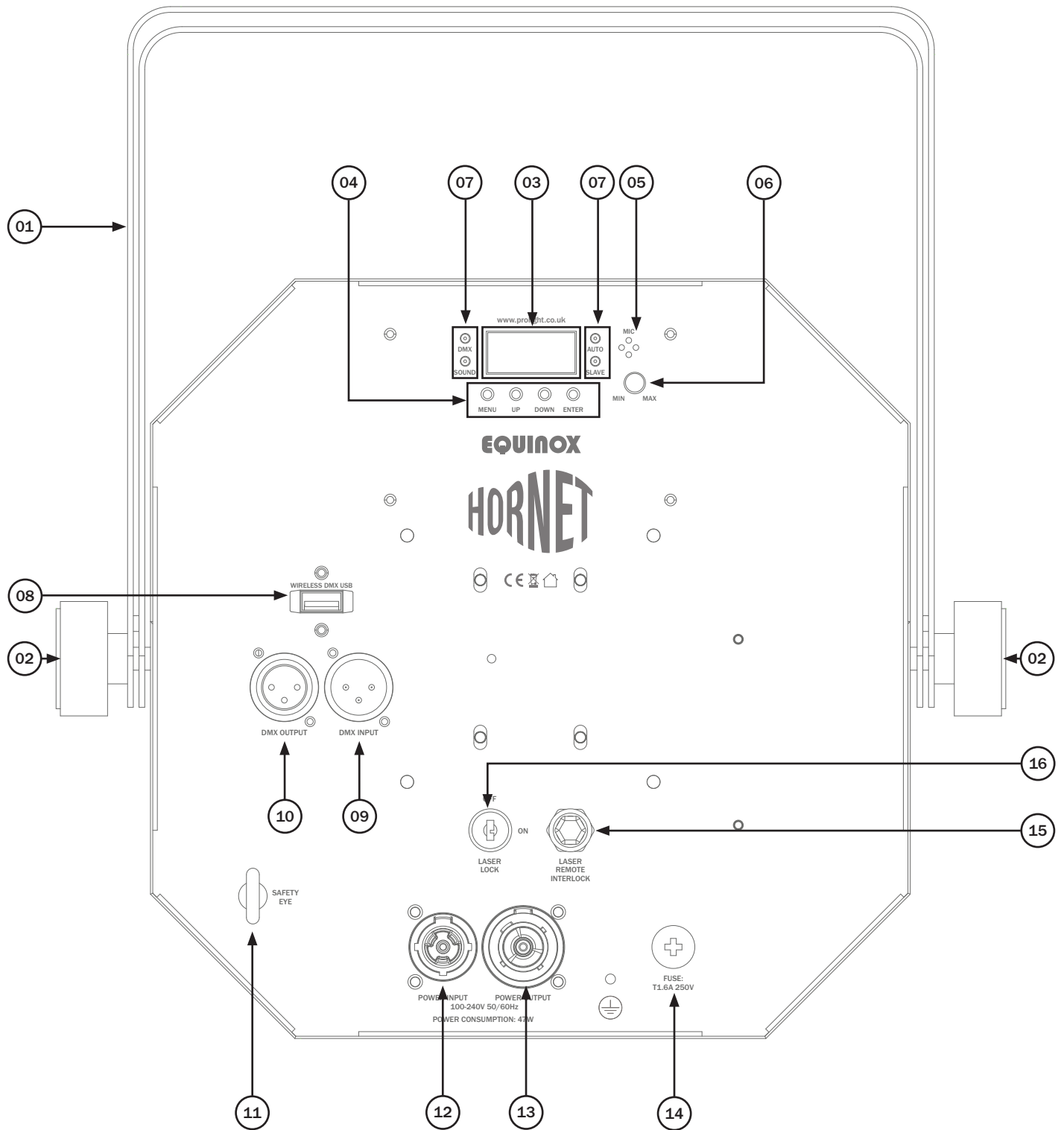

- 01 - Hanging bracket
- 02 - Hanging bracket adjustment knobs
- 03 - LED display
- 04 - Function buttons
- 05 - Microphone
- 06 - Microphone Sensitivity
- 07 - LED Mode Indicators
- 08 - Wireless DMX USB Port
- 09 - 3-Pin DMX input
- 10 - 3-Pin DMX output
- 11 - Safety Eye
- 12 - PowerTwist TR1 input
- 13 - PowerTwist TR1 output
- 14 - Fuse T1.6A 250V
- 15 - Laser Interlock
- 16 - Laser Lock

In the box: **1 x fixture,**
1 x power cable,
1 x IR remote,
1 x laser key,
1 x laser interlock

Installation:

1. Fasten the clamp to the bracket on the back of the fixture.
2. Mount the fixture onto your truss system via the clamps and tighten to ensure it is secure.
3. Pull the safety cable through the safety cable hole located on the metal base plate on the back of the fixture and around the truss.

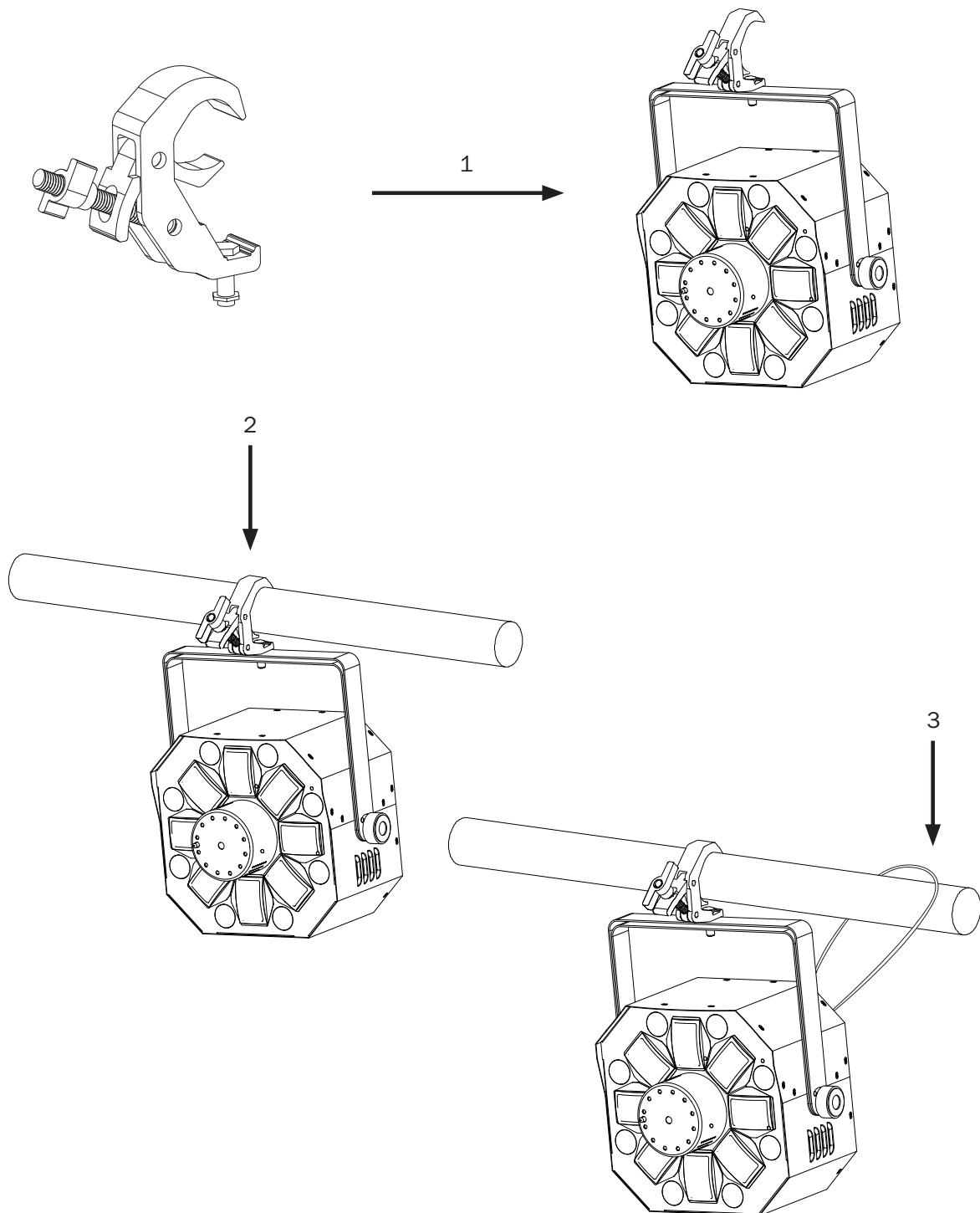

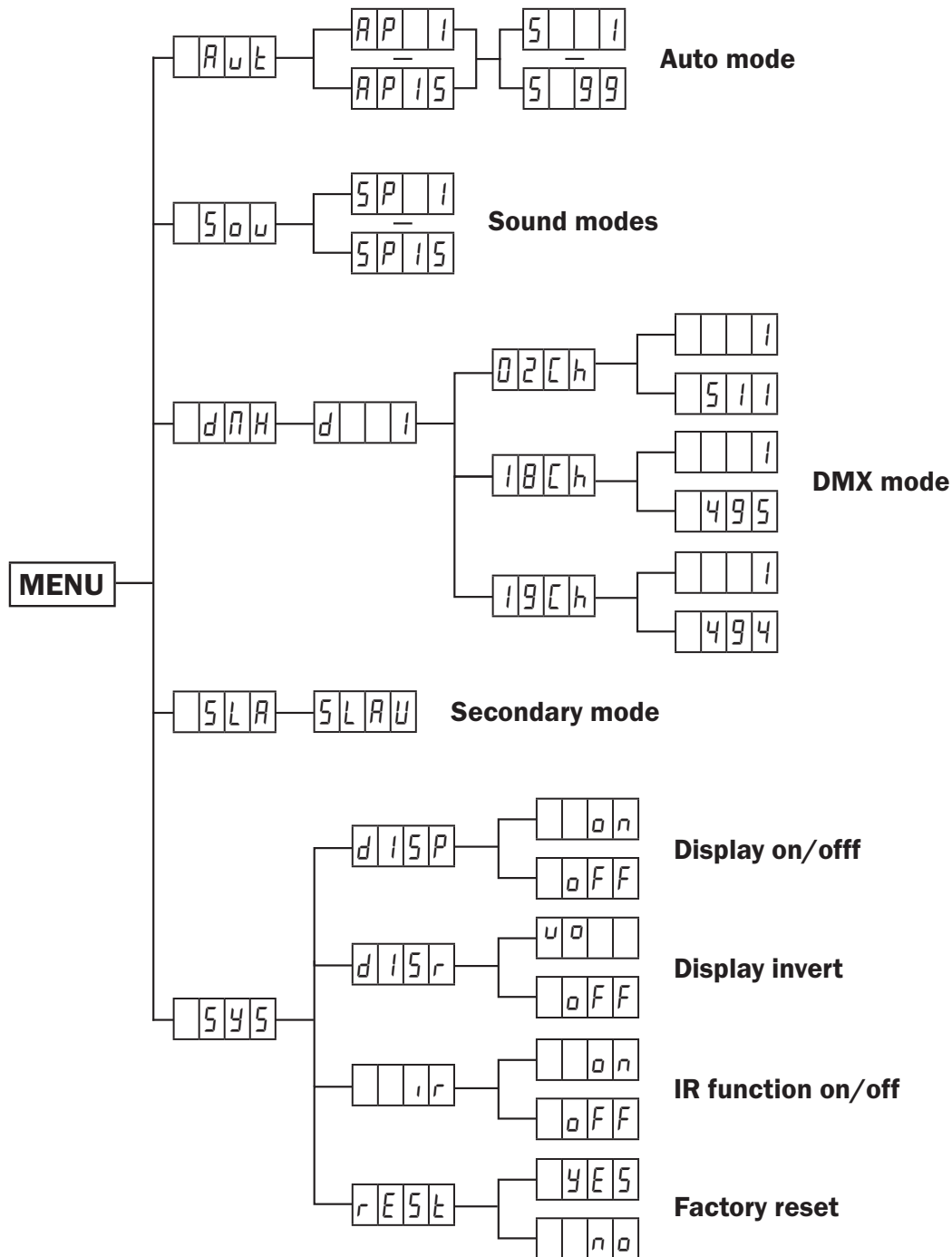

DMX mode:

Operating in a DMX control mode environment gives the user the greatest flexibility when it comes to customising or creating a show. In this mode you will be able to control each individual trait of the fixture and each fixture independently.

To access the DMX channel / address mode, press the “**MENU**” button and use the “**UP**” and “**DOWN**” buttons on the rear of the unit to show $d \Pi H$ on the LED display. Now press the “**ENTER**” button twice and use the “**UP**” and “**DOWN**” buttons to choose one of the 2, 18 or 19 DMX channel modes. Now press the “**ENTER**” button and use the “**UP**” and “**DOWN**” buttons to set the required DMX address. Press the “**ENTER**” button to confirm the setting. To exit out of any of the above options, press the “**MENU**” button

2 channel mode:

Channel	Value	Function
CH1	000-015	No function
	016-030	Program 1
	031-045	Program 2
	046-060	Program 3
	061-075	Program 4
	076-090	Program 5
	091-105	Program 6
	106-120	Program 7
	121-135	Program 8
	136-150	Program 9
	151-165	Program 10
	166-180	Program 11
	181-195	Program 12
	196-210	Program 13
	211-225	Program 14
226-255	Program 15	
CH2	000-200	Program speed (slow-fast)
	201-255	Program sound active

18 channel mode:

Channel	Value	Function
CH1	000-015	No function
	016-030	Program 1
	031-045	Program 2
	046-060	Program 3
	061-075	Program 4
	076-090	Program 5
	091-105	Program 6
	106-120	Program 7
	121-135	Program 8
	136-150	Program 9
	151-165	Program 10
	166-180	Program 11
	181-195	Program 12
	196-210	Program 13
	211-225	Program 14
226-255	Program 15	
CH2	000-200	Program speed (slow-fast)
	201-255	Program sound active
CH3	001-051	No function
	052-102	Red
	103-153	Green
	154-204	Blue
	205-255	UV
CH4	001-051	No function
	052-102	Red
	103-153	Green
	154-204	Blue
	205-255	UV
CH5	001-051	No function
	052-102	Red
	103-153	Green
	154-204	Blue
	205-255	UV
CH6	001-051	No function
	052-102	Red
	103-153	Green
	154-204	Blue
	205-255	UV

Channel	Value	Function
CH7	001-051	No function
	052-102	Red
	103-153	Green
	154-204	Blue
	205-255	UV
CH8	001-051	No function
	052-102	Red
	103-153	Green
	154-204	Blue
	205-255	UV
CH9	001-051	No function
	052-102	Red
	103-153	Green
	154-204	Blue
	205-255	UV
CH10	001-051	No function
	052-102	Red
	103-153	Green
	154-204	Blue
	205-255	UV
CH11	000-254	Washes strobe speed (slow-fast)
	255	Strobe sound active
CH12	000-009	No function
	010-014	Red
	015-019	Green
	020-024	Blue
	025-029	Amber
	030-034	White
	035-039	White + Red
	040-044	Red + Green
	045-049	Green + Blue
	050-054	Blue + Amber
	055-059	Amber + White
	060-064	White + Green
	065-069	Green + Amber
070-074	Amber + Red	
075-079	Red + Blue	
080-084	Blue + White	

18 channel mode (cont.)

Channel	Value	Function	
CH12 (cont.)	085-089	Red + Green + Blue	Derby
	090-094	Red + Green + Amber	
	095-099	Red + Green + White	
	100-104	Red + Amber + Blue	
	105-109	Red + White + Blue	
	110-114	Red + Amber + White	
	115-119	Amber + Green + Blue	
	120-124	Blue + Green + White	
	125-129	Amber + Green + White	
	130-134	Amber + White + Blue	
	135-139	Red + Green + Blue + Amber	
	140-144	Red + Green + Blue + White	
	145-149	Green + Blue + Amber + White	
	150-154	Red + Green + Amber + White	
	155-159	Red + Blue + Amber + White	
	160-164	Red + Green + Blue + Amber + White	
165-209	Auto mode - single colours (slow-fast)		
210-222	Auto mode - two colours (slow-fast)		
223-225	Sound mode		
CH13	000-004	No function	
	005-200	Strobe speed (fast-slow)	
	201-255	Strobe sound active	
CH14	000-004	No function	
	005-127	Motor rotation clockwise (slow-fast)	
	128-133	Motor rotation stop	
	134-255	Motor rotation counter-clockwise (slow-fast)	

Channel	Value	Function	
CH15	000-009	No function	Strobe
	010-019	Program 1 (fast-slow)	
	020-029	Program 2 (fast-slow)	
	030-039	Program 3 (fast-slow)	
	040-049	Program 4 (fast-slow)	
	050-059	Program 5 (fast-slow)	
	060-069	Program 6 (fast-slow)	
	070-079	Program 7 (fast-slow)	
	080-089	Program 8 (fast-slow)	
	090-099	Program 9 (fast-slow)	
	100-109	Program 10 (fast-slow)	
	110-119	Program 11 (fast-slow)	
	120-200	Full on	
	201-255	Sound active	
CH16	000-009	No function	Laser
	010-049	Red	
	050-089	Green	
	090-129	Green, red (alternate strobe)	
	130-169	Red on, green strobe	
	170-209	Green on, red strobe	
	210-255	Red, green strobe	
CH17	000-004	No function	Laser
	005-254	Strobe speed (fast-slow)	
	225	Strobe sound active	
CH18	000-004	No function	Laser
	005-127	Motor rotation clockwise (slow-fast)	
	128-133	Motor rotation stop	
	134-255	Motor rotation counter-clockwise (slow-fast)	

19 channel mode:

Channel	Value	Function
CH1	000-255	Master dimmer (0-100%) - Derby & wash
CH2	000-015	No function
	016-030	Program 1
	031-045	Program 2
	046-060	Program 3
	061-075	Program 4
	076-090	Program 5
	091-105	Program 6
	106-120	Program 7
	121-135	Program 8
	136-150	Program 9
	151-165	Program 10
	166-180	Program 11
	181-195	Program 12
	196-210	Program 13
	211-225	Program 14
226-255	Program 15	
CH3	000-200	Program speed (slow-fast)
	201-255	Program sound active
CH4	001-051	No function
	052-102	Red
	103-153	Green
	154-204	Blue
	205-255	UV
CH5	001-051	No function
	052-102	Red
	103-153	Green
	154-204	Blue
	205-255	UV
CH6	001-051	No function
	052-102	Red
	103-153	Green
	154-204	Blue
	205-255	UV
CH7	001-051	No function
	052-102	Red
	103-153	Green
	154-204	Blue
	205-255	UV

Channel	Value	Function
CH8	001-051	No function
	052-102	Red
	103-153	Green
	154-204	Blue
CH9	205-255	UV
	001-051	No function
	052-102	Red
	103-153	Green
CH10	154-204	Blue
	205-255	UV
	001-051	No function
	052-102	Red
CH11	103-153	Green
	154-204	Blue
	205-255	UV
	001-051	No function
CH12	000-254	Washes strobe speed (slow-fast)
	255	Strobe sound active
CH13	000-009	No function
	010-014	Red
	015-019	Green
	020-024	Blue
	025-029	Amber
	030-034	White
	035-039	White + Red
	040-044	Red + Green
	045-049	Green + Blue
	050-054	Blue + Amber
	055-059	Amber + White
	060-064	White + Green
	065-069	Green + Amber
	070-074	Amber + Red
	075-079	Red + Blue
080-084	Blue + White	

19 channel mode (cont.)

Channel	Value	Function	
CH13 (cont.)	085-089	Red + Green + Blue	Derby
	090-094	Red + Green + Amber	
	095-099	Red + Green + White	
	100-104	Red + Amber + Blue	
	105-109	Red + White + Blue	
	110-114	Red + Amber + White	
	115-119	Amber + Green + Blue	
	120-124	Blue + Green + White	
	125-129	Amber + Green + White	
	130-134	Amber + White + Blue	
	135-139	Red + Green + Blue + Amber	
	140-144	Red + Green + Blue + White	
	145-149	Green + Blue + Amber + White	
	150-154	Red + Green + Amber + White	
	155-159	Red + Blue + Amber + White	
	160-164	Red + Green + Blue + Amber + White	
	165-209	Auto mode - single colours (slow-fast)	
	210-222	Auto mode - two colours (slow-fast)	
223-225	Sound mode		
CH14	000-004	No function	
	005-200	Strobe speed (fast-slow)	
	201-255	Strobe sound active	
CH15	000-004	No function	
	005-127	Motor rotation clockwise (slow-fast)	
	128-133	Motor rotation stop	
	134-255	Motor rotation counter-clockwise (slow-fast)	

Channel	Value	Function	
CH16	000-009	No function	Strobe
	010-019	Program 1 (fast-slow)	
	020-029	Program 2 (fast-slow)	
	030-039	Program 3 (fast-slow)	
	040-049	Program 4 (fast-slow)	
	050-059	Program 5 (fast-slow)	
	060-069	Program 6 (fast-slow)	
	070-079	Program 7 (fast-slow)	
	080-089	Program 8 (fast-slow)	
	090-099	Program 9 (fast-slow)	
	100-109	Program 10 (fast-slow)	
	110-119	Program 11 (fast-slow)	
	120-200	Full on	
	201-255	Sound active	
CH17	000-009	No function	Laser
	010-049	Red	
	050-089	Green	
	090-129	Green, red (alternate strobe)	
	130-169	Red on, green strobe	
	170-209	Green on, red strobe	
	210-255	Red, green strobe	
CH18	000-004	No function	Laser
	005-254	Strobe speed (fast-slow)	
	225	Strobe sound active	
CH19	000-004	No function	Laser
	005-127	Motor rotation clockwise (slow-fast)	
	128-133	Motor rotation stop	
	134-255	Motor rotation counter-clockwise (slow-fast)	

Auto mode:

To access the auto modes, press the “MENU” on the rear of the unit button and use the “UP” and “DOWN” buttons to show *AUT* on the LED display. Now press the “ENTER” button and use the “UP” and “DOWN” buttons to choose between *AP 1 ~ AP 15*. Now press the “ENTER” button and use the “UP” and “DOWN” buttons to set the speed between *5 1 ~ 5 99*. Press the “ENTER” button to confirm the setting.

To exit out of any of the above options, press the “MENU” button.

Sound active mode:

To access the sound active mode, press the “MENU” button on the rear of the unit and use the “UP” and “DOWN” buttons to show *SOU* on the LED display. Now press the “ENTER” button and use the “UP” and “DOWN” buttons to keep between *SP 1* or *SP 15*. Press the “ENTER” button to confirm the setting. To exit out of any of the above options, press the “MENU” button.

To adjust the sound sensitivity, use the MIN/MAX potentiometer on the rear of the fixture.

Secondary mode:

To set the unit in secondary mode, press the “MENU” button on the rear of the unit and use the “UP” and “DOWN” buttons to show *SLA* on the LED display. Press the “ENTER” button to confirm the setting. The unit will now run in sequence with a primary unit.

To exit out of any of the above options, press the “MENU” button.

Please ensure that all secondary units are set to the same DMX channel mode as the primary unit.

LED display:

To access the LED display setting, press the “MENU” button on the rear of the unit to show *545* on the LED display. Press the “ENTER” button and use the “UP” and “DOWN” buttons to show *d1 5P* on the LED display. Now press the “ENTER” button and use the “UP” and “DOWN” buttons to set the LED display *on* or *off*. Press the “ENTER” button to confirm the setting.

To exit out of any of the above options, press the “MENU” button.

LED Display inversion:

To invert the LED display, press the “MENU” button on the rear of the unit to show *545* on the LED display. Press the “ENTER” button and use the “UP” and “DOWN” buttons to show *d1 5r* on the LED display. Now press the “ENTER” button and use the “UP” and “DOWN” buttons to set the LED display to *off* (normal) or *u* (inverted.) Press the “ENTER” button to confirm the setting.

To exit out of any of the above options, press the “MENU” button.

IR remote control:

To activate the IR remote functionality press the “**MENU**” button on the rear of the unit to show **555** on the LED display. Press the “**ENTER**” button and use the “**UP**” and “**DOWN**” buttons to show **ir** on the LED display. Now press the “**ENTER**” button and use the “**UP**” and “**DOWN**” buttons to set the IR remote functionality to **on** or **OFF**. Press the “**ENTER**” button to confirm the setting.

To exit out of any of the above options, press the “**MENU**” button.

Factory reset:

To restore the fixture to factory settings, press the “**MENU**” button on the rear of the unit to show **rESt** on the LED display. Now press the “**ENTER**” button and use the “**UP**” and “**DOWN**” to choose between **YES** or **no**. Press the “**ENTER**” button to confirm the setting.

To exit out of any of the above options, press the “**MENU**” button.

IR remote functions:

- 01 - Sets the unit into auto mode (press multiple times to cycle through the 7 auto modes)
- 02 - Sets the unit into sound mode (press multiple times to cycle through the 7 sound modes)
- 03 - Sets the unit into blackout on or off
- 04 - Sets the derby colour in manual mode (use the +/- to select a colour) - laser is always on in this mode
- 05 - Press to pause the running of auto or sound mode
- 06 - Turns on/off the wash.
- 07 - Turns on/off the derby.
- 08 - Turns on/off the laser.
- 09 - Turns on/off the strobe.

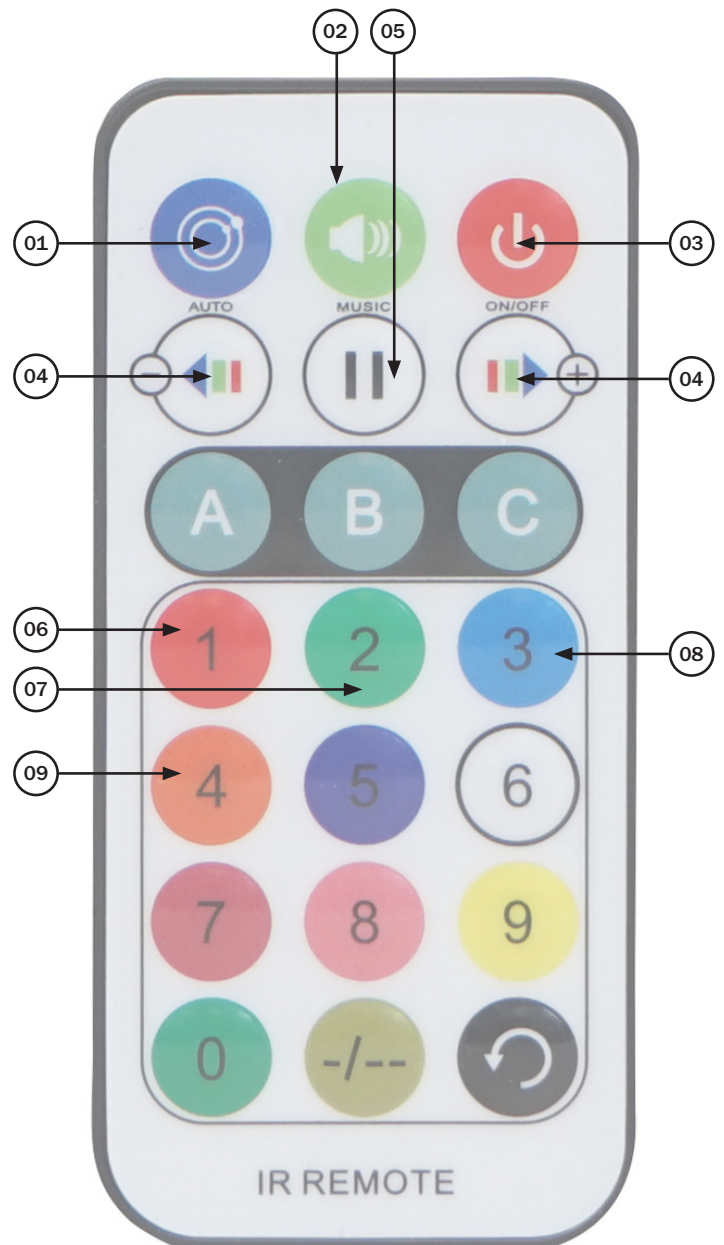

Wireless operation:

To operate the fixture (sold separately) wirelessly you will need to plug in the W-DMX Compatible USB Transceiver into the USB port on the rear of the fixture. W-DMX should also be set to “ON” in the fixtures settings (full instructions can be in the fixtures manual).

If using it in wireless DMX mode a compatible wireless DMX Transmitter (e.g. Wireless Solutions Sweden or Lumen Radio) will need to be connected.

The W-DMX Compatible USB Transceiver features 2 operating protocols as listed below.

The LED on the side of the dongle will illuminate a different colour for each operating protocol.

W-DMX G3 Transmit Protocol - Blue (when transmitting)

W-DMX Receive Protocol - Green (when receiving)

To set the dongle in one of these modes plug the W-DMX Compatible USB Transceiver into the USB port on the rear of the fixture. Press the button on the dongle whilst powering on the unit.

The LED will illuminate white for a brief moment and then change colour. You can then press the button which will scroll through the operating protocols. Once you have selected the chosen protocol, press and hold the button on the dongle for 3 seconds. The LED will illuminate white, then turn blue (transmit mode) or stay white (receive mode). The unit is now set in your chosen protocol.



W-DMX G3 Transmit Protocol:

Once in this protocol the LED will illuminate blue. This indicates the fixture is ready to pair with the receiver(s). Once all the receiver(s) have been set up press the button on the dongle once and the LED will flash blue quickly, this indicates it is attempting to pair with the receivers. Once pairing is complete the LED will illuminate static blue to indicate the fixture is transmitting signal.

To disconnect the transmitting fixture from all receiving fixtures within range when connected, hold the button on the transmitting fixtures dongle down for 3 seconds until the LED illuminates red.

This indicates the wireless memory has been cleared.

W-DMX Receive Protocol:

Once in this protocol the LED will illuminate white. This indicates a connection has not yet been established with the transmitter. Once the transmitter has been set up press the button on the transmitter fixtures dongle once or press the pair button on your wireless transceiver. The LED on the receiving units will flash green quickly, this indicates it is attempting to pair with the transmitter. Once pairing is complete the LED will illuminate static green to indicate the fixture is receiving signal.

To disconnect the transmitting fixture from all receiving fixtures within range when connected, hold the button on the transmitting fixtures dongle down for 3 seconds until the LED illuminates white.

This indicates the wireless memory has been cleared.

If the indicator on the receiving units flashes red quickly this indicates that the signal from the transmitting fixture has been lost.

Setting the DMX address:

The DMX mode enables the use of a universal DMX controller. Each fixture requires a “start address” from 1- 512. A fixture requiring one or more channels for control begins to read the data on the channel indicated by the start address. For example, a fixture that occupies or uses 7 channels of DMX and was addressed to start on DMX channel 100, would read data from channels: 100, 101, 102, 103, 104, 105 and 106. Choose a start address so that the channels used do not overlap. E.g. the next unit in the chain starts at 107.

DMX 512:

DMX (Digital Multiplex) is a universal protocol used as a form of communication between intelligent fixtures and controllers. A DMX controller sends DMX data instructions from the controller to the fixture. DMX data is sent as serial data that travels from fixture to fixture via the DATA “IN” and DATA “OUT” XLR terminals located on all DMX fixtures (most controllers only have a data “out” terminal).

DMX linking:

DMX is a language allowing all makes and models of different manufactures to be linked together and operate from a single controller, as long as all fixtures and the controller are DMX compliant. To ensure proper DMX data transmission, when using several DMX fixtures try to use the shortest cable path possible. The order in which fixtures are connected in a DMX line does not influence the DMX addressing. For example; a fixture assigned to a DMX address of 1 may be placed anywhere in a DMX line, at the beginning, at the end, or anywhere in the middle. When a fixture is assigned a DMX address of 1, the DMX controller knows to send DATA assigned to address 1 to that unit, no matter where it is located in the DMX chain.

DATA cable (DMX cable) requirements (for DMX operation):

This fixture can be controlled via DMX-512 protocol. The DMX address is set on the back of the unit. Your unit requires a standard 3-pin connector for data input/output, see image below.



Further DMX cables can be purchased from all good sound and lighting suppliers or Prolight Concepts dealers.
Please quote: 3-Pin: **CABL10 - 2m** **CABL11 - 5m** **CABL12 - 10m**

Also remember that DMX cable must be daisy chained and cannot be split.

Notice:

Be sure to follow the diagrams below when making your own cables. Do not connect the cables shield conductor to the ground lug or allow the shield conductor to come in contact with the XLRs outer casing. Grounding the shield could cause a short circuit and erratic behaviour.

Pin Configuration	
3-Pin	5-Pin
	Pin 1 - Ground
	Pin 2 - Negative
	Pin 3 - Positive
-	Pin 4 - N/C
-	Pin 5 - N/C

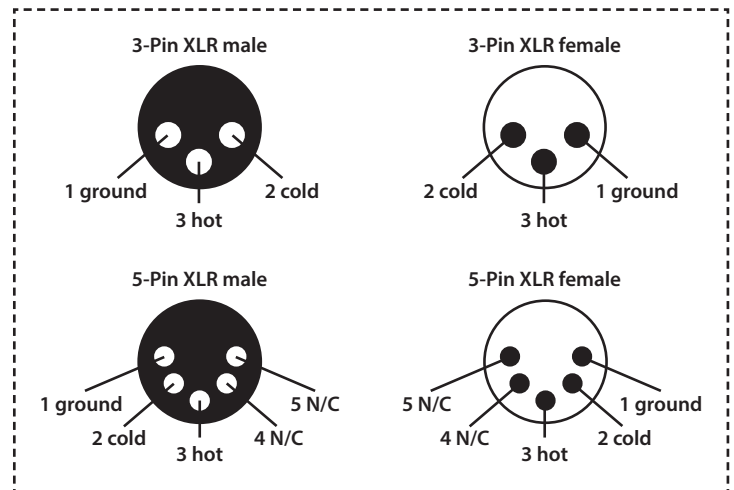
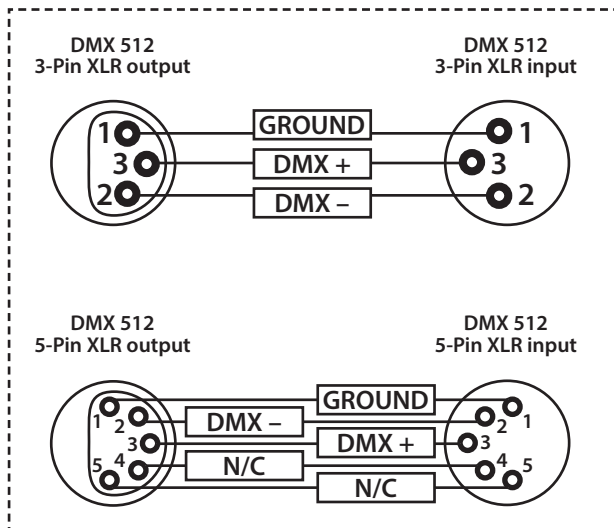

Line termination:

When longer runs of cable are used, you may need to use a terminator on the last unit to avoid erratic behaviour.

Using a cable terminator will decrease the possibilities of erratic behaviour.

(3-pin - Order ref: CABL90,
5-pin - Order ref: CABL89)

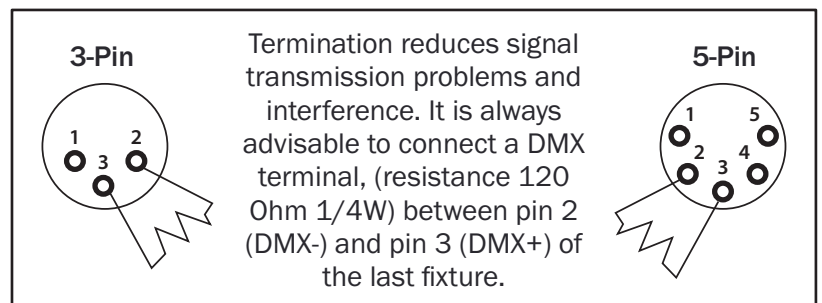

5-pin XLR DMX connectors:

Some manufactures use 5-pin XLR connectors for data transmission in place of 3-pin. 5-pin XLR fixtures may be implemented in a 3-pin XLR DMX line. When inserting standard 5-pin XLR connectors in to a 3-pin line a cable adaptor must be used. The diagram below details the correct cable conversion.

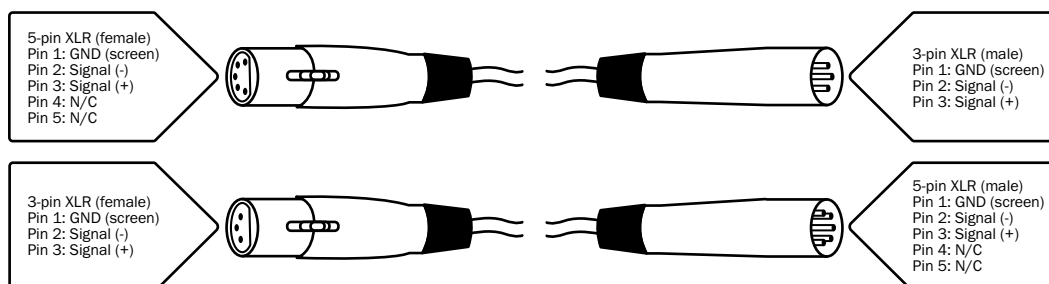

Power linking:

This fixture provides power linking via the power output on the rear allowing multiple units to be connected together. The maximum number of fixtures that can be connected is 24 fixtures @ 240V or 12 fixtures @ 120V (including the first fixture). After the maximum number of fixtures are connected a new power run will need to be started.

Please note: Caution should be used when power linking other fixtures to the Hornet as the power consumption of other fixtures will vary. Fixtures fitted with lamps often require 2/3 times more current on startup, these may require their own power source.

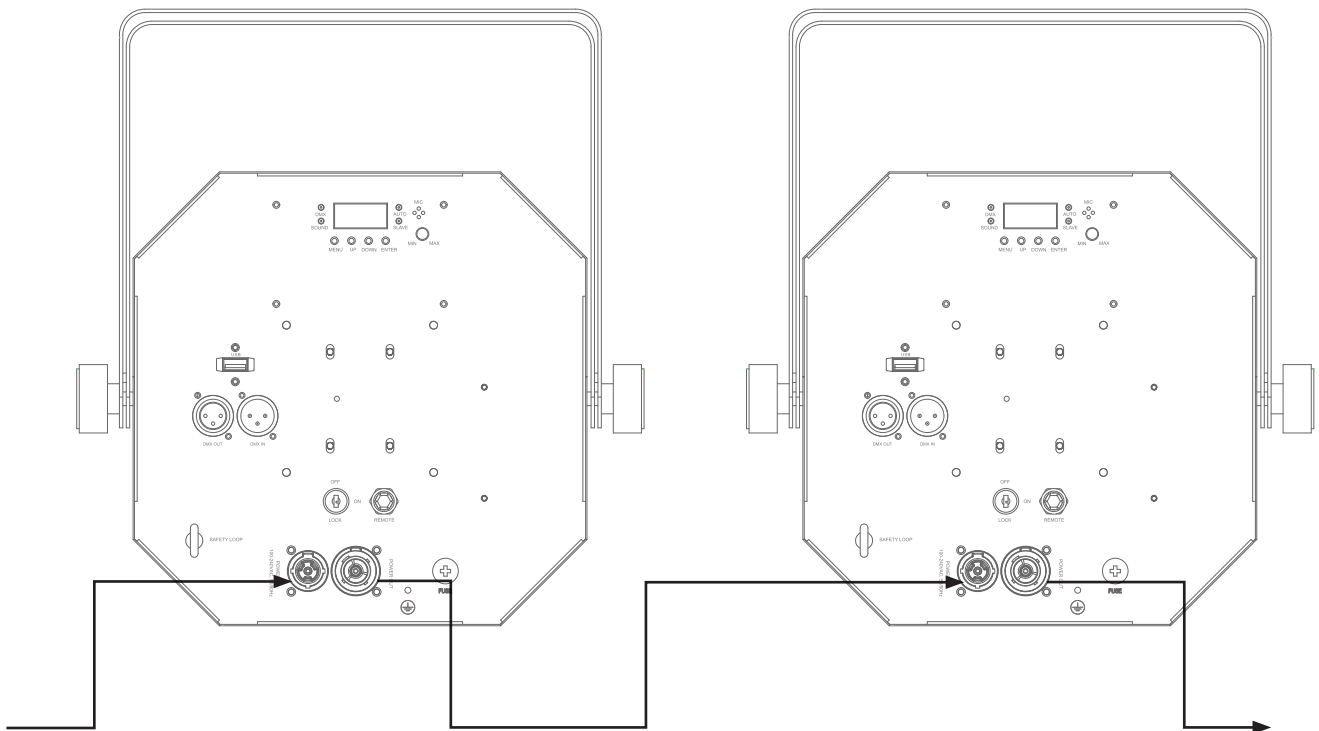



Correct Disposal of this Product (Waste Electrical & Electronic Equipment)

**(Applicable in the European Union and other European countries
with separate collection systems)**

This marking shown on the product or its literature, indicates that it should not be disposed of with other household wastes at the end of its working life. To prevent possible harm to the environment or human health from uncontrolled waste disposal, please separate this from other types of wastes and recycle it responsibly to promote the sustainable reuse of material resources.

Household users should contact either the retailer where they purchased this product, or their local government office, for details of where and how they can take this item for environmentally safe recycling.

Business users should contact their supplier and check the terms and conditions of the purchase contract. This product should not be mixed with other commercial wastes for disposal.

